

SPECIFICATION:

MATERIALS:
 Seat Ends - Recycled Cast aluminium
 Timbers - Hardwood Timber
 Straps - Mild steel
 Fixings - Zinc

DIMENSIONS:
 mm unless otherwise stated

FINISH:
 Castings - Powder Coat or Mill Finish
 Strap - Powder Coat
 Timber - Oil Based

GROUND FIXING:
 Bolt down

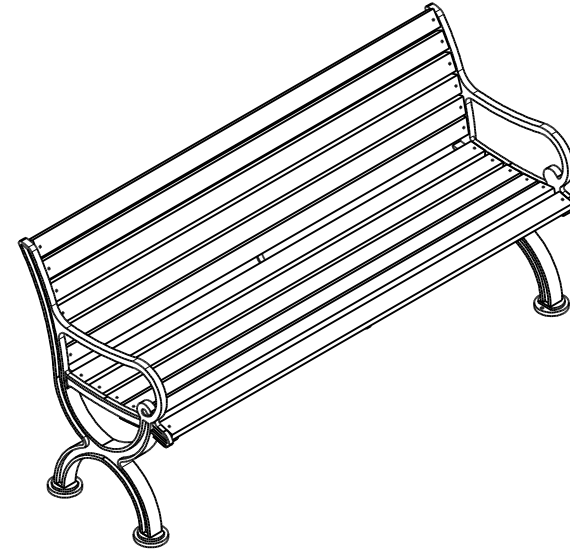

Quality
 ISO 9001
 SAI GLOBAL

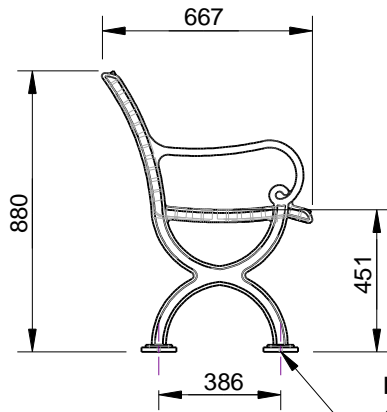

BOLT DOWN DETAIL

Ø10 THRU
 4 LOCATIONS

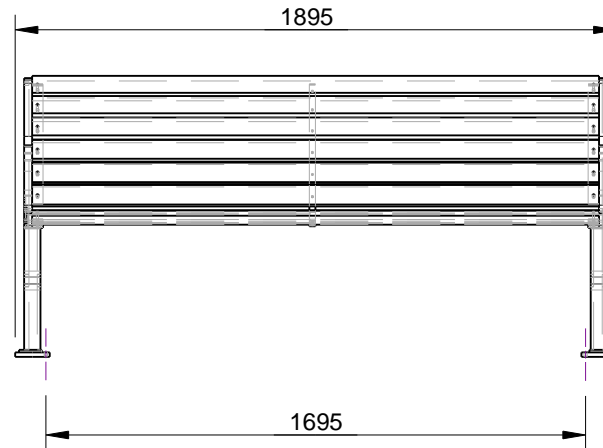

CONFIDENTIAL

REVISION #	DESCRIPTION	BY	DATE	DRAWN	DRAWN DATE	CHECKED	CHECKED DATE	SCALE	A4
								N/A	
1	ORIGINAL DRAWING	DN	14.10.10	R.CRIGTON	2.12.13				
2	FULL PRODUCT REVIEW	RBC	2.12.13						
3									
4									
5									

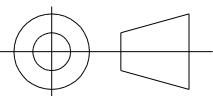

SOUTHBANK SEAT
 SPEC.

FFSA002012

REV.
 2

SHEET
 1 OF 3